

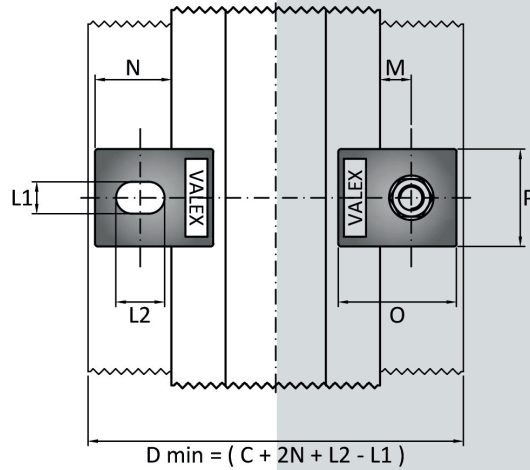

RAIL WITHOUT PAD

RAIL WITH PAD



RAIL WITHOUT PAD

RAIL WITH PAD

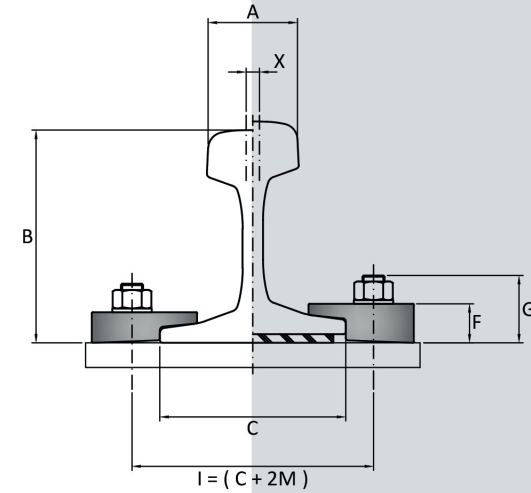

FEATURES

- System made up of one clip one bolt and nut.
- Possibility of lateral adjustment.
- Easy and simple installation.
- Easy and simple maintenance.

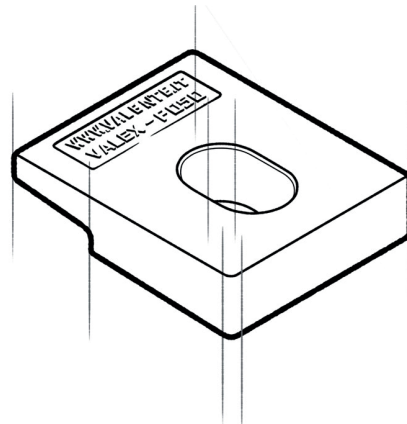

COMPONENTS

- Clip

APPLICATIONS

VALEX F050 is a direct fastening system specifically developed for crane rails, however, it can also be used for train and light (Decauville) rails, with very positive results. A very rugged, reliable system of contained dimensions, which can be used with every type of crane, independently of the driving system.

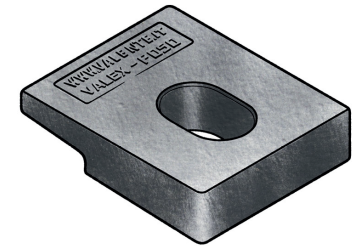

Dimensions [mm]	E	F	G	H	L	L1	L2	M	N	O	P	Weight [g]
VALEX F050	-	21	50	-	-	23	35	22,5	55	85	70	670



RAIL TYPE	A	B	C	Weight [kg/m]	WITH PAD	WITHOUT PAD
	[mm]	[mm]	[mm]			
A 45	45,00	55,00	125,00	22,10	-	VALEX F050
A 55	55,00	65,00	150,00	31,80	-	VALEX F050
A 65	65,00	75,00	175,00	43,10	-	VALEX F050
A 75	75,00	85,00	200,00	56,20	-	VALEX F050
A 100	100,00	95,00	200,00	74,30	-	-
A 120	120,00	105,00	220,00	100,00	-	-
A 150	150,00	150,00	220,00	150,30	-	-
CR 104	63,50	127,00	127,00	51,59	-	-
CR 105	65,10	131,80	131,80	52,09	-	-
CR 135	76,20	146,00	131,80	66,97	-	-
CR 171	101,60	152,40	152,40	84,83	-	-
MRS 87 A	101,60	152,40	152,40	86,80	-	-
CR 175	102,40	152,40	152,40	86,80	-	-
MRS 125	120,00	180,00	180,00	125,00	-	-
S 7	25,00	65,00	50,00	6,75	-	-
S 10	32,00	70,00	58,00	10,00	-	-
S 14	38,00	80,00	70,00	14,00	-	-
S 18	43,00	93,00	82,00	18,30	-	-
S 20	44,00	100,00	82,00	19,80	-	-
S 24	53,00	115,00	90,00	24,43	-	VALEX F050
25 kg/m	50,00	115,00	90,00	25,00	-	VALEX F050
S 26 (AFNOR 26)	50,00	110,00	100,00	26,27	-	VALEX F050
27 E1 (27 UNI)	50,00	120,00	95,00	27,06	-	VALEX F050
AFNOR 30	56,00	125,50	106,00	29,98	-	VALEX F050
30 E1 (S 30)	60,30	108,00	108,00	30,13	-	VALEX F050
33 E1 (S 33)	58,00	134,00	105,00	33,47	-	VALEX F050
36 E1 (36 UNI)	60,00	130,00	100,00	36,26	-	-
40 E1 (S 41-R14)	67,00	138,00	125,00	40,95	-	VALEX F050
46 E4 (46 UNI)	65,00	145,00	135,00	46,90	-	-
49 E1 (S 49)	67,00	149,00	125,00	49,39	-	-
50 E5 (50 UNI)	67,00	148,00	135,00	49,90	-	VALEX F050
54 E1 (UIC 54)	70,00	159,00	140,00	54,77	-	VALEX F050
60 E1 (UIC 60)	72,00	172,00	150,00	60,21	-	-



GENERAL INSTRUCTIONS

The selection of the fastening system, either for crane, train, or light (Decauville) rails, is a critically important decision both when placing a track or a single rail. The wrong selection could have expensive consequences and create serious problems such as:

- Slow down or shut down of the production process
- Excessive and, or irregular wear of the rails
- Damage of the mechanical components of the crane
- Damage of the supporting base
- Damage of the fastening systems

Valex fastening systems were developed through experience accumulated over more than 100 years of activity.

Valex fastening systems offer a wide range of alternatives, which would perform in the most effective and efficient way in every possible situation.

FIXING DETAILS

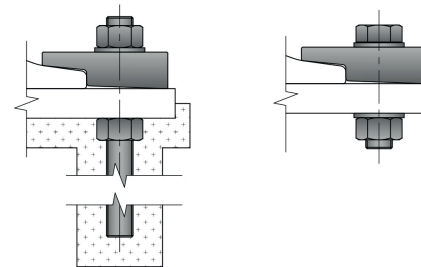

VALENTE S.p.A. aims to provide maximum assistance and total customer satisfaction, guarantees the origin and quality of its products, and supplies any reasonably requested documentation.

VALENTE S.p.A. reserves the right to modify the information contained in the technical data sheet without notice and disclaims any responsibility for any inaccuracies or changes in the reported data.

INSTALLATION INSTRUCTIONS

- Carefully align the rails.
- Place the clips in direct contact with the rails.
- Position the washer and insert the screw.
- Perform an initial light tightening.
- Complete the tightening process according to recommended torque.

TECHNICAL SPECIFICATIONS

- Side load 70 KN
- Lateral adjustment 8 mm
- Torque tightening 320 Nm
- Bolt 8.8 gr M20 – NOT INCLUDED
- Steel quality S275JR

Valex fastening systems can also be used for several other rail profiles, not listed. A complete range of compatible rails is available on request.